

## Multi-contact plug

### For barriers of the PARKING P 2500 - P 4000 series



DISCOVER  
ONLINE



### Plug connection for protecting the barrier boom cabling

The multi-contact plug is a dedicated solution specifically developed for ELKA barriers of the PARKING P 2500 - P 4000 series.

It serves as the wiring interface between the housing and the barrier boom and ensures a reliable electrical connection for supplying the LED boom lighting. In the standard configuration, the wires are assigned to two LED colors (red and green) as well as the boom missing contact function.

If required, the boom missing contact can be deactivated by reconfiguring the wiring on site and be replaced by a third LED color (blue).



In the event of a collision, such as when the barrier boom is struck, the plug connection disconnects in a controlled manner. This protects the supply lines from damage and prevents the cables from being torn off. The boom missing contact reports the fault to the control unit, enabling the barrier to stop automatically.

#### At a glance:

- Protection of supply lines through controlled disconnection in the event of damage
- Integrated boom missing contact
- Suitable for ELKA barriers of the PARKING P 2500 - P 4000 series
- In combination with vandalism protection screws (plastic)
- Not suitable for articulation set-ups or articulation barriers



## Multi-contact plug

### Functionality

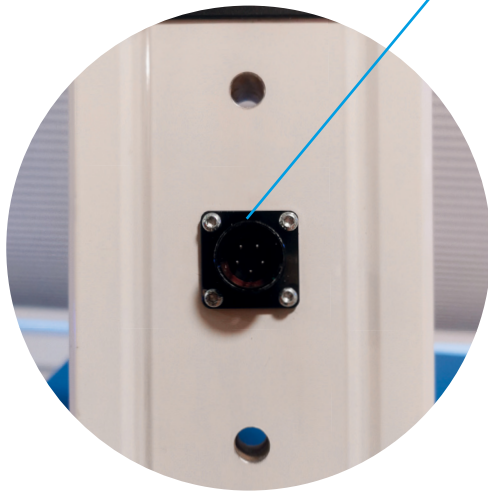

Multi-contact plug in the barrier boom



Multi-contact plug in the boom holder

### Operating Principle and Construction

The multi-contact plug consists of two components. The plug is installed in the boom and wired to the LED boom lighting. The socket is located in the boom holder of the barrier and is connected to the supply lines of the housing.

When the barrier boom is inserted, the two parts are connected, establishing the electrical connection between the boom and the housing. At the same time, the circuit required

for the boom missing contact is closed. The barrier boom is secured to the boom holder using three plastic screws with stainless steel lock nuts. This fastening point is designed as a defined breaking point.

In the event of a collision, this ensures damage-free separation of the electrical connection as well as the controlled detachment of the boom from the housing.

### Optimum protection in the event of damage

- Predetermined separation point for damage mitigation
- Controlled disconnection of the supply lines at the interface
- Immediate stopping of the barrier

# Technical Data

Key Features	
LED lighting	2 colours (Red, Green) / 3 colours (Red, Green, Blue)
Boom disconnection detection function	available, 2-color LED lighting
Compatible series	PARKING
Compatible boom types	Standard boom (boom profile 100×25mm) with plastic fastening screws

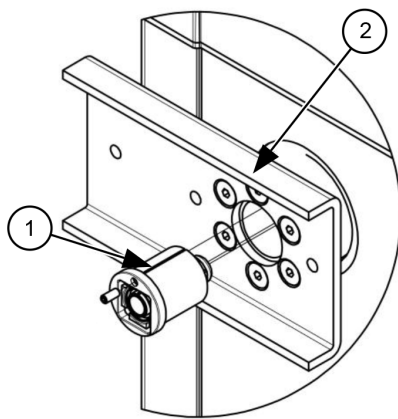

- 1 Multi-contact plug
- 2 Boom holder with plastic fastening screws

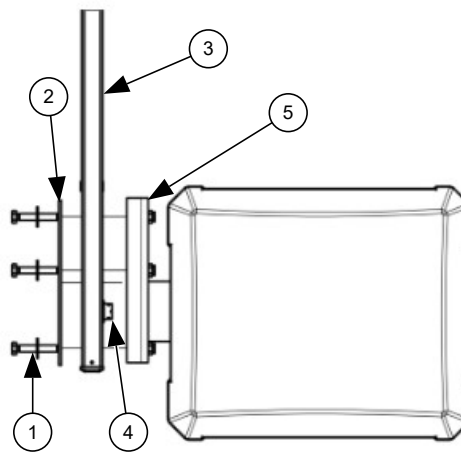

- 1 Plastic screws
- 2 Reinforcement plate on the barrier boom
- 3 Barrier boom
- 4 Multi-contact plug
- 5 Boom holder



## ELKA TORANTRIEBE

**For more than 45 years, ELKA stands for quality “Made in Germany”**

As an experienced manufacturer, we develop high-quality barrier systems for parking lots, parking garages, commercial entrances and toll stations, robust traffic bollards for reliable protection in pedestrian zones and entrances, high-performance gate drive technology and suitable accessories for modern access control solutions - innovative and designed to meet the highest demands. Our products are developed and manufactured in Germany and are subject to strict quality controls - this enables us to achieve maximum reliability for daily use.

“Partner with competence” - this philosophy is firmly anchored in our corporate culture. Fast order processing, short delivery times and adherence to delivery dates are a matter of course for us. We supply to customers in over 80 countries worldwide and provide them with experienced advice. Our experts know every product in detail and are happy to support you in planning your projects. Contact us - we look forward to hearing from you.

You can find further information on our website: [www.elka.eu](http://www.elka.eu)

✓ **Competent customer service**

✓ **Quality „Made in Germany”**

✓ **Short delivery times and adherence to delivery dates**



ELKA-Torantriebe GmbH u. Co. Betriebs KG  
Dithmarscher Str. 9, 25832 Tönning

✉ [info@elka.eu](mailto:info@elka.eu) ☎ +49 (0) 4861-9690-0

🌐 [www.elka.eu](http://www.elka.eu) 📠 +49 (0) 4861-9690-90